

Automatic by-pass valve

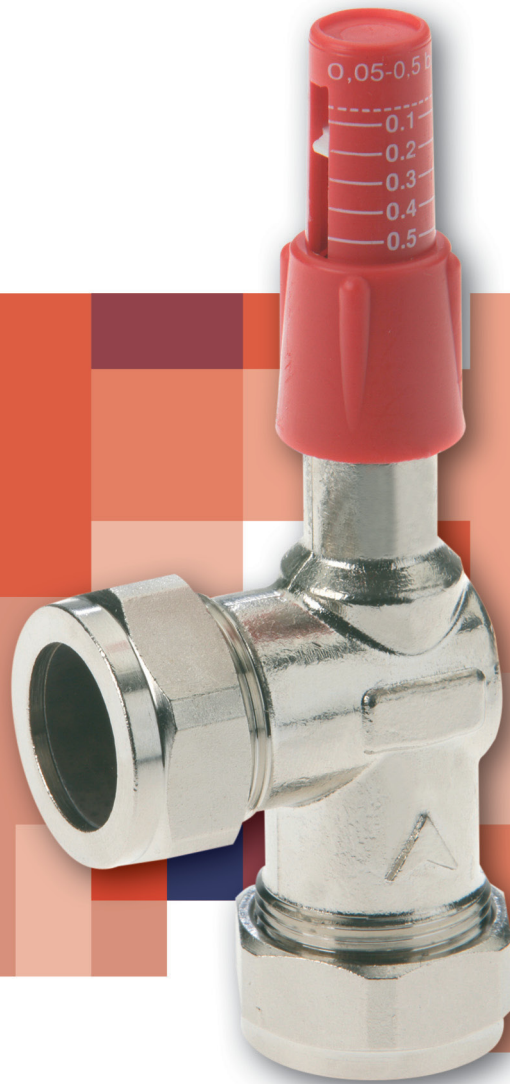

The Drayton automatic by-pass valve is designed to maintain a minimum flow rate in heating systems fitted with thermostatic radiator valves.

By-pass valve

Features

- Maintains optimum flow
- Automatic operation
- Set and forget
- Ensures quiet operation
- High quality
- Reliable

Application

The DTB automatic by-pass valve is designed to maintain a minimum flow rate in heating systems fitted with thermo-static radiator valves. When all the TRVs are open the by-pass valve remains closed, allowing the full boiler output to circulate around the heating system. As TRVs sense that selected room temperatures are reached and start to close, the by-pass valve starts to open, maintaining optimum flow through the boiler and so eliminating possible damage to the boiler and pump. Installation of the DTB by-pass valve will minimise noise often experienced when flow through the boiler decreases.

Installation

The by-pass should be installed between the flow and return with flow in the direction of the arrow. If a higher capacity is required for large installations it is possible to install two or more valves in parallel.

Setting

The valve can be manually adjusted from 0.05 Bar to 0.5 Bar. The graph opposite shows the flow curves of the settings at 0.1, 0.2, 0.3, 0.4 and 0.5 Bar. A setting of 0.2 – 0.3 Bar is sufficient for most common installations. If the differential pressure is too low or the by-pass flow is too high, the pressure setting should be increased. If the differential pressure is too high or the by-pass flow too low, the pressure setting should be decreased.

Technical data

Connections	22mm compression joints
Setting range	0.05 to 0.5 Bar
Working pressure	16 bar
Working temp.	120°C Intermittent

Dimensions (mm)

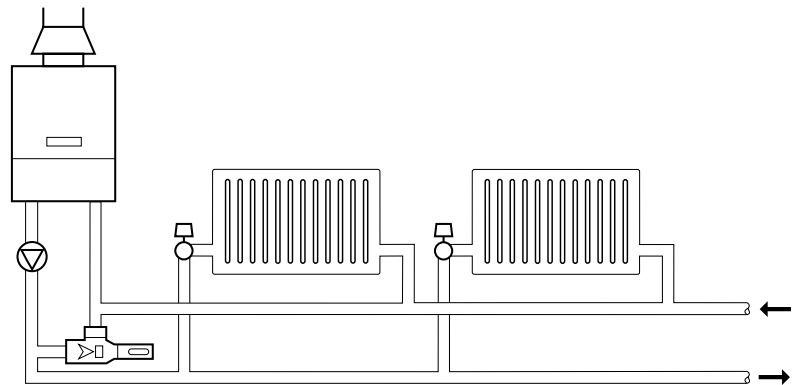
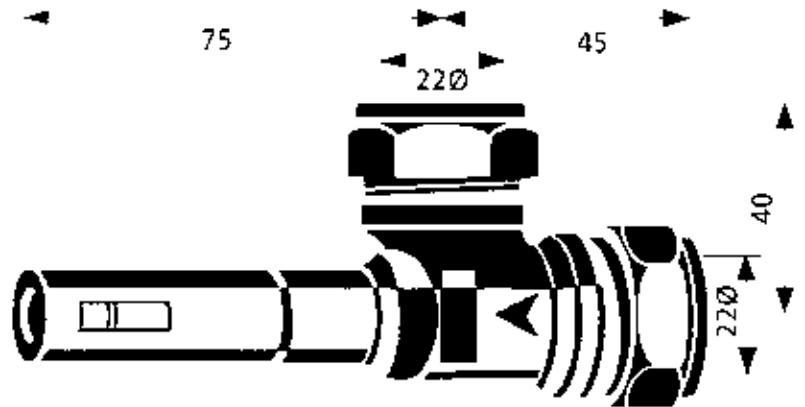

invenSYS
Controls

Customer Service Tel: 0845 130 5522
 Customer Service Fax: 0845 130 0622
 Technical Helpline Tel: 0845 130 7722
 Email: customer.care@invensys.com
 Website: www.draytoncontrols.co.uk

Available from:



D30-7