

Gravity tapstat cylinder controller

General Description

The Drayton 1" Gravity Tapstat Controller is a self-operating valve with remote sensing for controlling gravity-circulated domestic hot water primary systems and is specially designed to control the temperature of the domestic hot water supply on combined heating and hot water systems at 60°C (140°F) approximately.

Description of operation

When the sensor is correctly installed, heat is transmitted from the tank wall to the sensor, causing an expansion of the liquid in the sensor, and this is used to operate the control valve to regulate the amount of water flowing through the inner heating coil or annulus of the cylinder.

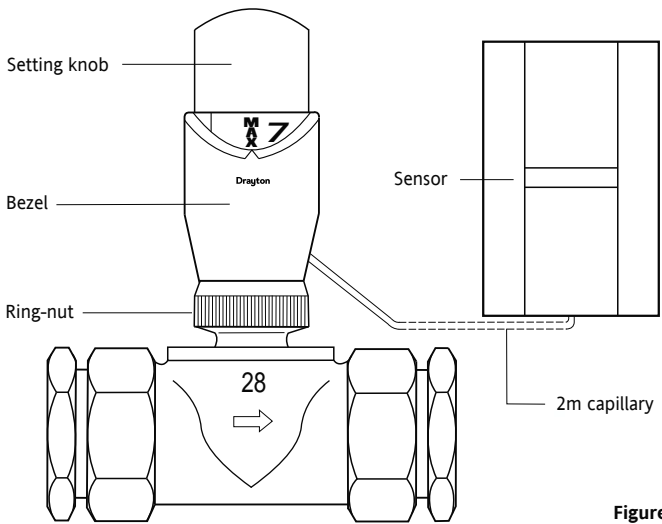

Figure 1

Installation

The valve should be installed as in the alternatives shown in Fig. 2 with the setting knob in the most convenient position, and the flow in the direction of the arrows. Care must be taken when using jointing compound to avoid any excess being transferred to the valve seat as this will prevent the valve closing. DO NOT FIT CAPILLARY FITTINGS to these valves as excessive heat from the blow torch may damage the valve seating.

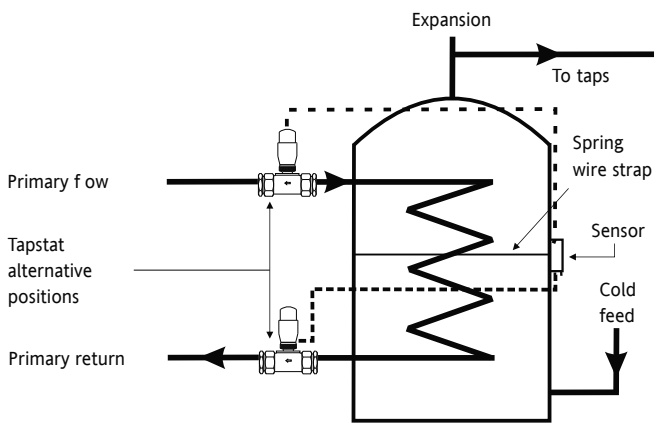

Figure 2

If the setting scale is not visible after the tapsat is installed, the ring nut may be slackened and the head assembly rotated. Re-tighten the ring nut.

The capillary tubing joining the valve to the sensor must be free to move vertically up and down in the slot in valve head and therefore must not be clipped, with the fittings provided, closer than 150mm from the valve. This is important for correct valve operation.

Care should be taken when handling the capillary, particularly to avoid kinking or re-bending a number of times. Surplus capillary must not be cut - coil any surplus.

The sensor should be positioned approximately half-way up the side of the hot water cylinder, in direct contact with the cylinder wall. It must be kept well away from the primary flow and return connections and firmly clamped in position as shown in Fig. 3.

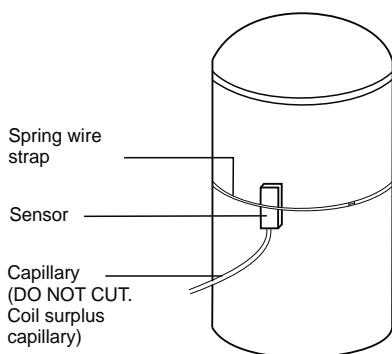

Figure 3

If a square tank is used, e.g. on district heating schemes, the sensor should be clamped approximately half-way up the side of the hot water section. It is recommended that the lagging jacket is fitted to the cylinder over the top of the sensor.

Setting

The valve leaves the factory set to a range of approximately 32-72°C (90-162°F) indicated by numbers from 1 to 7 and max. on the setting scale.

Commissioning

Check that the sensor is firmly clamped to the cylinder surface and is well away from the primary flow and return connections.

The best setting of the thermostat will normally be determined by trial and error, but it is suggested that the setting knob should initially be turned to number 3. A higher cylinder temperature may be obtained by resetting to a higher number.

When selecting a different number it is advisable to draw off some hot water and sufficient time must be allowed for the cylinder to achieve the new conditions before the future adjustments are made.

Locked Setting and limited setting range

The setting knob can be locked at any number, or the adjustment restricted, to a shorter range than the full scale adjustment from 1 to max.

1. Turn setting knob to symbol "MAX". Slacken the bezel retaining screw sufficient for the bezel to be lifted as far as it will move. Unscrew the setting knob and bezel as one unit, ensuring the capillary is sliding in its slot and NOT rotating with the bezel and knob. The plastic component with its main thread will be left attached to the valve body.

2. Slide the head away from the bezel, taking care not to over-bend the capillary. Two tubular pins will be seen inside the bezel, and these may be repositioned as required for range limited or locking. Each number on the external setting scale has a corresponding number on the bezel to assist in positioning the pins.

Lock setting: Reposition the tubular pins on either side of the number at which you wish to lock the valve. Refit bezel with lug between the pins.

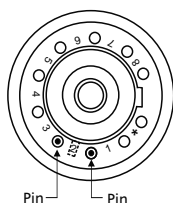

Numbers indicate indexing positions corresponding to external scale.

Diagram shows head lock set on number 2.

Figure 4

Range limiting: Reposition the pins in the holes outside the minimum and maximum setting numbers required. Refit bezel with lug between the pins.

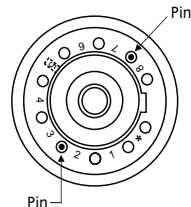

Numbers indicate indexing positions corresponding to external scale.

Diagram shows head range set between numbers 3 and 7.

Figure 5

3. IMPORTANT. Reposition white plastic bezel, ensuring that the two tubular pins are outside the protruding lug on the sensing head.

Maintenance No periodic maintenance is required.

Spare parts Head, complete with sensor. Valve body complete.

Optional extras Pocket for immersion sensor. Recommended where flow temperatures are likely to exceed 100°C (212°F).

Drayton

401 Southway Drive
Plymouth
PL6 6QT
United Kingdom

Technical Helpline: 0333 7000 622

Website: www.draytoncontrols.co.uk

Email: customer.care@draytoncontrols.co.uk

@DraytonControls

/DraytonControls

982 307 348 Issue E