



Auto-balancing Thermostatic Radiator Valves

Drayton

by **Schneider** Electric

Introducing the new Drayton Auto-balancing TRVs



Made for energy efficiency

A balanced heating system is an efficient one. Industry states that an average 8.8% of energy waste can be saved by ensuring the heating system is fully balanced. With the new Auto-balancing TRVs, this is quick and simple to ensure and maintain.

Made for simplicity

The new Drayton Auto-balancing TRV turns a time consuming and complex process into a quick and permanent solution that helps reduce energy bills and ensures every room is perfectly heated – reducing customer call-backs.

Made for UK homes

Designed specifically for the UK residential market, Drayton Auto-balancing TRVs look almost identical to the much-loved TRV4 and RT414. Similarly to these well-known models, the new auto-balancing valve will fit directly onto standard pipe sizes without having to change a thing. Ideal for a retrofit where Drayton TRVs are already installed.

Why is the auto-balancing valve the ideal solution?

- Reduces energy use by 8.8%
- Saves installation time as flow rate is set when fitting the valve
- Automatically adjusts radiators according to pressure changes / TRVs opening and closing
- Permanently maintains correct flow to each radiator
- Ensures lower return flow temperatures to aid condensing – improving boiler efficiency
- Eliminates cold spots around the home
- Use new Drayton balancing key to adjust setting

Auto-balancing TRV4



Product	Part No.
Auto-balancing TRV4 Angle with lockshield	07 05 560
Auto-balancing TRV4 Straight with lockshield	07 05 561

Features:

- Keymark approved to EN215
- Drayton's iconic TRV4 design
- Sensitive liquid-filled sensor
- Full/half click stop settings
- Frost protection position
- Lead-free brass valve body

Auto-balancing RT414



Product	Part No.
Auto-balancing RT414 angle with lockshield	10 10 560
Auto-balancing RT414 straight with lockshield	10 10 561

Features:

- Entry level option
- Keymark approved to EN215
- Sensitive liquid-filled sensor
- Frost position
- Positive OFF position
- Lead-free brass valve body

Valve bodies

Valve bodies are also available to purchase on their own, for retrofit solutions.

Product	Part No.
Auto-balancing 15mm angle valve	07 15 560
Auto-balancing 15mm straight valve	07 15 561

Getting technical

AUTO-BALANCING TRVs	TRV4	RT414
Maximum Sensor Temperature	50	50
Setting numbers	1 to 5 then "MAX"	OFF then 1 to 6
Temperature range	10-30°C	12-29°C
*Frost Protection	Below 8°C	Below 8°C
Sensitivity	0.22mm/°C	0.22mm/°C

VALVES	
Maximum flow temperature	110°C
Maximum static pressure	10 bar at 65°C, 6 bar at 110°C
Maximum differential pressure	0.6 bar

EN215 KEYMARK TEST	TRV4	RT414
Hysteresis	0.4K	0.35K
Water temperature influence	0.8K	1K
Differential pressure influence	0.15K	0.15K
Response time	20 mins	22 mins
Control accuracy	0.6	0.6

Setting values with different radiator performances and system differential temperatures

Q̇ [W]	Δt=10 K	Δt=15 K	Δt=20 K
200	2	1	1
250	2	1	1
300	3	2	1
400	3	2	2
500	3	3	2
600	5	3	3
700	6	4	3
800	7	5	3
900	8	5	4
1000	9	6	4
1200	10	7	5
1400	12	8	6
1600	14	9	7
1800	15	10	8
2000		12	9
2200		13	10
2400		14	10
2600		15	11
2800			12
3000			13
3200			14
3400			15

Example:
 $Q̇ = 1000 \text{ W}$
 $\Delta t = 15 \text{ K}$
 Setting value: 6
 (≈ 60 l/h)

1 - 10 l/h
 ...
 5 = 50 l/h
 ...
 10 - 100 l/h
 ...
 15 - 150 l/h

Δp min.
 10-100 l/h
 = 0.1 bar

Δp min.
 100-150 l/h
 = 0.15 bar

Δp max.
 = 0.6 bar

$Q̇$ = Radiator performance, Δt = System differential temperature, Δp = Differential pressure

How we measure up

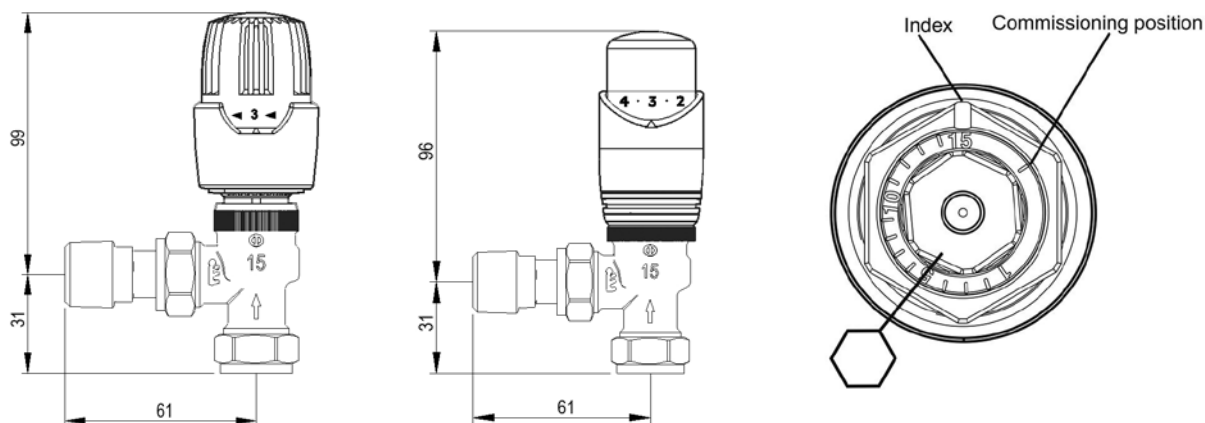

draytoncontrols.co.uk

Customer & Technical Support: 0333 6000 622

D129-2

In accordance with our continuous improvement procedures, we reserve the right to change design features and specifications without prior notification. The Data contained in this document is for guidance only. Drayton accepts no liability for any consequential losses, injury or damage resulting from the use of this document or the information contained within.



Join The Drayton Community
 Facebook Group

Drayton

by Schneider Electric